

EN

07.2023



Elastomer Jaw Couplings RINGFEDER® TNM G

Installation and Operation Manual



Content

Chapter	Page
1 Notes on safety	2
2 Function	3
2.1 Appropriate Use	3
3 Marking of the coupling	4
4 Storage.....	4
5 Construction	5
6 Technical data.....	6
7 Assembly.....	8
7.1 Pay attention before the assembly	8
7.2 Finished borehole.....	9
7.3 Installing coupling.....	10
8 Adjusting coupling	12
8.1 Angular misalignment ΔK_w	13
8.2 Radial displacement ΔK_r	13
8.3 Axial displacement	14
9 Operation	15
9.1 Sense of rotation test	18
10 Maintenance.....	20
10.1 Wear Inspection on the Buffer Ring	20
10.2 Wear limit of elastic buffers	21
10.3 Changing the elastic intermediate ring	21
11 Waste Disposal	23

1 Notes on safety

The present assembly and operating instruction (AOI) constitutes a part of the coupling supply. Always keep the AOI near the coupling well accessible.

The German version of this manual is the predominant and binding version.

Make sure that all persons charged with the assembly, operating, service, and maintenance have read and understood the AOI and follow all the points:

- Avert hazards for body and live of the user and third parties.
- Ensure the operating safety of the coupling.
- Avoid the loss of use and environmental impairment through false handling.

In the case of transport, mounting, dismounting and maintenance, attention is to be paid to the relevant regulations for industrial safety and for environmental care.

The coupling may only be operated, mounted, serviced and maintained by authorised and trained personnel.

The user must take into account that the bolting elements of coupling parts may be adversely affected by the heat produced by a brake disk/ brake drum due to the resultant friction. Make sure that the combination of the employed brake lining with the material of the brake disk/ brake drum does not lead to sparks or impermissible thermal growth. The brake disk is

normally made of steel, and the brake drum is normally made of cast iron with nodular graphite. In case of any doubt, please consult the supplier!

In the interest of further development, we reserve the right to make changes which serve technological progress.

By the use of accessories and spare parts, which were not originally manufactured by RINGFEDER POWER TRANSMISSION, we are not responsible for any resulting damage or liability or guarantee.

2 Function

The coupling RINGFEDER® TNM G is a torsionally elastic and puncture-proof claw coupling.

It balances out angular, radial, and axial shaft misalignments within defined limits. The coupling transfers the torque via pressure loadable, elastic buffers or Perbunan (Pb) which are joined together as an intermediate ring.

The elastic intermediate ring can cushion impacts and torsional vibrations; it is oil-tight and electrically conductive.

A coupling half is divided in two and allows through this a simple separation of the coupled machine. With the claw ring pulled back it is possible to check the rotational direction of the drive. It is also possible to lift out radially a coupling half with accompanying aggregate. The elastic intermediate ring can be changed without axially shifting the machine.

The coupling is usable in every sense of rotation and installation position.

2.1 Appropriate Use

- In order to ensure a faultless, lasting operation of the coupling it must be laid out according to the layout instructions e.g. DIN 730 part 2 (or also Product Paper & Tech Paper
- "Elastomer Jaw Couplings") with an operating factor corresponding to the operating conditions.
- The coupling must only be operated in normal industrial atmospheres. Since aggressive media may attack the coupling components, screws and elastic buffer rings, they represent a risk for the operational safety of the coupling. Consult RINGFEDER POWER TRANSMISSION in such cases.
- Apart from incorporating a finished bore hole with parallel key groove (see "7.2 Finished borehole") no further changes can be carried out on the coupling.
- The coupling may only be used within the framework of the conditions defined in the performance and delivery contract.
- Every change of the conditions of use or the operating parameters necessitates a new verification of the coupling layout.

3 Marking of the coupling

The product line RINGFEDER® TNM has its hardness in Shore (A) indicated on the elastic intermediate ring.

4 Storage

On receipt of the goods, the supply is to be checked immediately for completeness and correctness. Possible damages incurred during transit and / or missing parts are to be notified in writing.

The coupling parts can be stored in their delivered standard-state for 6 months in a dry, roofed place at normal room temperature. For a longer storage duration a long-term preservation is necessary (consult RINGFEDER POWER TRANSMISSION). The elastic intermediate ring must not be subjected to ozone containing mediums, direct solar influence or strong light sources with ultraviolet-light. The relative humidity must not exceed 65%. In the case of proper storage the characteristics of the elastic intermediate ring remain unchanged for almost up to three years.

phuongphat www.pnp-thietbi.com 0964900401

5 Construction

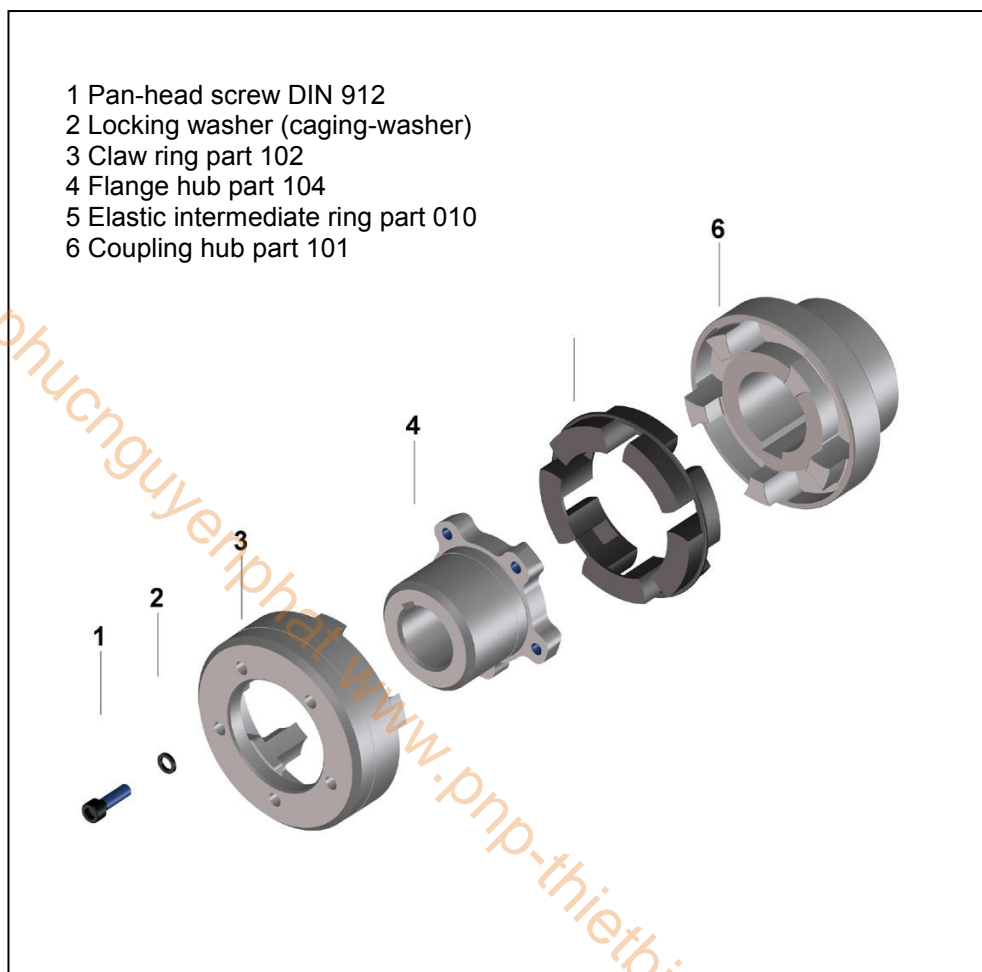

Fig. 1 Construction RINGFEDER® TNM G

Details:

Claw ring (Pos. 3) and flange hub (Pos. 4) are delivered screwed together.
 Balanced parts are position marked to each other.

6 Technical data

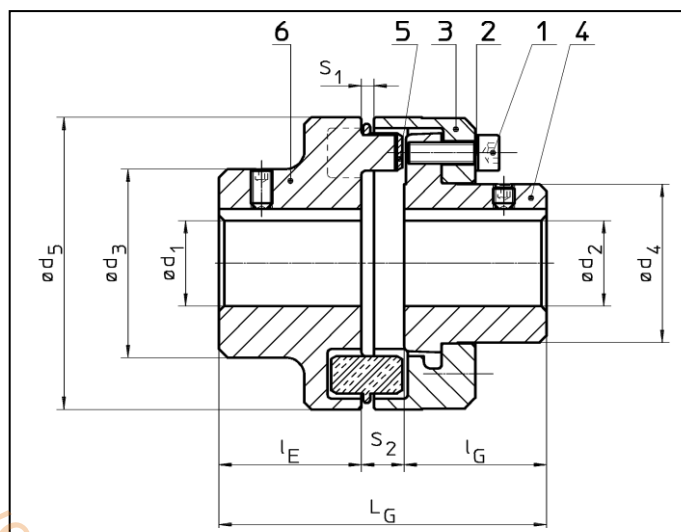

Fig. 2 RINGFEDER® TNM G

Table 1 Technical data:

Size TNM G	T _{Cnom} Pb72 [Nm]	T _{Cpeak} Pb72 [Nm]	T _{Cnom} Pb82 [Nm]	T _{Cpeak} Pb82 [Nm]	n _{max} [min ⁻¹]	d ₁ max [mm]	d ₂ max [mm]	d ₃ [mm]
82	48	100	75	150	5000	32	32	53
97	96	200	150	210	5000	42	39	69
112	150	310	230	540	5000	48	46	79
128	250	500	380	650	5000	55	53	90
148	390	800	600	1350	4500	65	65	107
168	630	1300	980	1800	4000	75	75	124
194	1050	2000	1650	2400	3500	85	85	140
214	1500	3100	2400	4200	3000	95	95	157
240	2400	4800	3700	6200	2750	110	100	179
265	3700	7500	5800	8300	2500	120	115	198
295	4900	10000	7550	10500	2250	130	130	214
330	6400	13000	9900	14500	2000	150	135	248
370	8900	18200	14000	20000	1750	170	160	278
415	13200	27000	20500	27000	1500	190	180	315
480	18000	36000	28000	66000	1400	210	200	315
575	27000	54000	41000	97500	1200	230	260	350

Size Nor-Mex G	d ₄ [mm]	d ₅ [mm]	l _E [mm]	l _G [mm]	L _G [mm]	S ₁ [mm]	S ₂ [mm]	m undrilled [kg]
82	44,5	82	40	40	92	3,0	12	2,0
97	54,5	97	50	49	113	3,0	14	3,4
112	64,5	112	60	58	133	3,5	15	5,5
128	74,5	128	70	68	154	3,5	16	8,3
148	92,5	148	80	78	176	3,5	18	13,1
168	104,5	168	90	87	198	3,5	21	19,4
194	121,5	194	100	97	221	3,5	24	28,5
214	135,5	214	110	107	243	4,0	26	38,8
240	146,0	240	120	117	267	4,0	30	52,4
265	164,0	265	140	137	310	5,5	33	75,3
295	181,0	295	150	147	334	8,0	37	97,3
330	208,0	330	160	156	356	8,0	40	130,0
370	241,0	370	180	176	399	8,0	43	183,6
415	275,0	415	200	196	441	8,0	45	258,2
480	289,0	480	220	220	485	8,0	45	346,5
575	370,0	575	240	240	525	8,0	45	528,8

The torque T_{Cnom} and T_{Cmax} is valid for:

- Intermediate rings of Perbunan Pb72 and/or Pb82,
- Ambient temperatures of -40 °C to $+60\text{ °C}$,
- Operation within the stipulated alignment values.

During the layout of the coupling according to DIN 740 part 2 (or also Product Paper & Tech Paper" Elastomer Jaw Couplings") different factors must be considered:

- with higher temperatures a corresponding temperature factor S_U
- according to the starting frequency a starting factor S_z
- in dependence of the operating conditions an impact factor, S_A , S_L

With circumferential speeds of more than 22 m/s, we recommend to balance the coupling.

phucnguyenphat www.pnp-thietbi.com 0964900401

7 Assembly

7.1 Pay attention before the assembly



- **Danger of injuries!**
- **Disconnect the drive before carrying out any work on the coupling!**
- **Secure the drive against unintentional re-start and rotation!**
- **Incorrectly tightened bolts can cause serious personal injuries and property damages!**
- **In compliance with accident prevention regulations, you are obliged to protect all freely rotating parts by means of permanently installed guards/ covers against unintentional contact and falling down objects.**
- **To avoid sparks, the covers for couplings used in explosive atmospheres should be made of stainless steel!**
- **As a minimum, the covers have to fulfil the requirements of protection type IP2X.**
 - **The covers have to be designed to prevent dust from depositing on the coupling.**
 - **The cover must not contact the coupling or impair the proper function of the coupling.**
- Make sure that the speeds, torques and ambient temperatures as stated in chapter 6 „Technical Data“ are not exceeded.
- The maximum permissible bore diameters must not be exceeded.
- Check whether the shaft-hub connections safely transmit the occurring operating torques.
- The standard tolerance of RINGFEDER® TNM for finish bores is fit H7.
- Standard keyways comply with DIN 6885, sheet 1.
- Check the dimensions and tolerances of shafts, hub bores, keys and keyways.
- Set screws as required.

7.2 Finished borehole

For the completion of the finished borehole in a coupling hub, pay attention to following procedure:

- Clean the coupling hub of preservatives.
- Tighten the coupling hub to the faces labelled with $\bar{\square}$ and carefully align the coupling hub.
- The indicated values in table 1 for $\varnothing d_{1max}$ and $\varnothing d_{2max}$ are valid for a parallel key connection according to DIN 6885/1 and must not be exceeded.
- Choose the borehole fit so that during the union with the shaft tolerance a wringing fit and/or an interference fit as for example at H7/m6 is carried out.
- Provide a setscrew for axial securing on the hub back above the parallel key slot.

In the case of other shaft hub connections consultation with RINGFEDER POWER TRANSMISSION is necessary.



- **The maximum indicated borehole diameters are valid for a parallel key connection according to DIN 6885/1 and must not be exceeded.**
- **In the case of transgression of these values the coupling can sever.**
- **Through flying away fragments danger exists!**

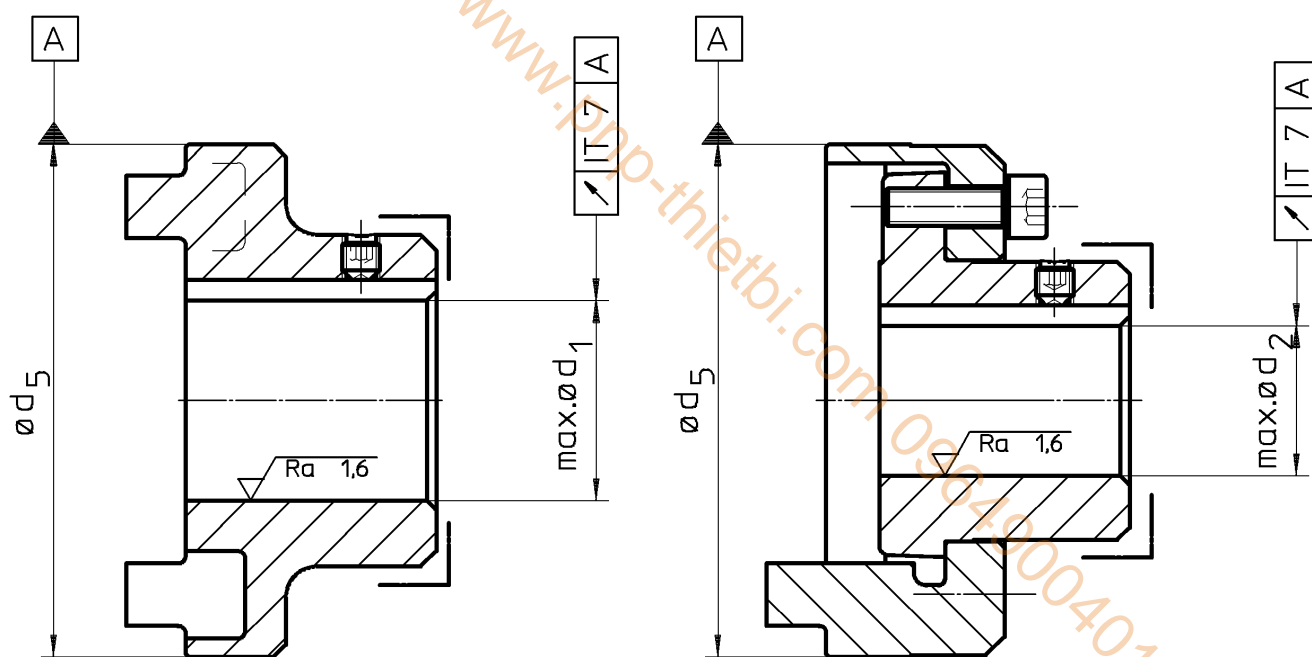

7.3 Installing coupling

- Remove the elastic intermediate ring (Figure 3, Pos. 1).
- Clean the borehole of the flange hub and the coupling hub and the shaft ends before installing. The surfaces must be clean, dry and grease-free.
- Use suitable installation aids and hoists such as cranes or pulley blocks in the case of bigger couplings.
- Pull the flange hub onto the shaft end in its intended position (Figure 3, Pos.2).

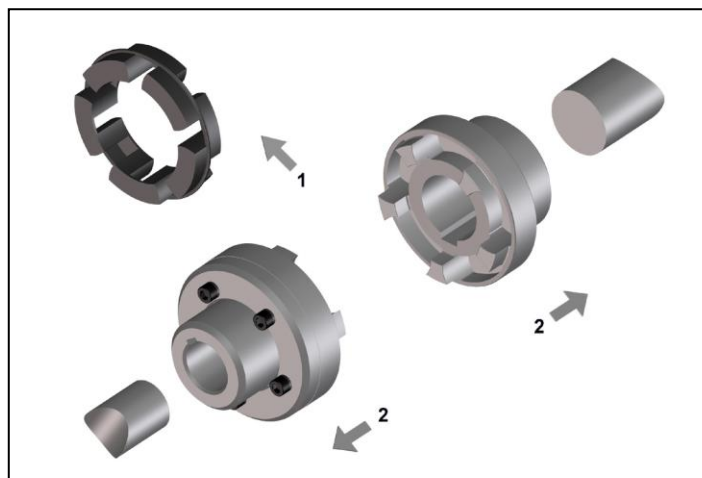

Fig. 3

Reference:

For easier installation a uniform warming of the hub to 80 °C to 120 °C is safe.



- **Warning!**
- **Only work with gloves as a protection against hot parts of the coupling!**

- Mount the hub so that the shaft ends are flush with the interior borehole opening (Figure 4). Pay attention to possible differing agreements!
- Secure possible available setscrews by tightening with an adhesive e.g. Loctite 222 against automatic loosening and flying out.

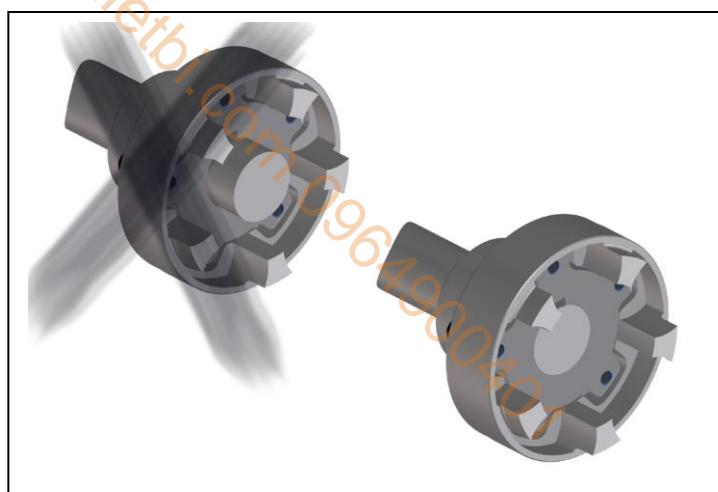

Fig. 4

ATTENTION!

Let the hot hubs cool off to ambient temperature before the introduction of the intermediate ring.

- For easier mounting the elastic intermediate ring can be provided with a slip additive (e.g. Talcum) before introduction.
- Fit the intermediate ring into one half of the coupling
- Push the shaft ends with the mounted coupling halves together (Figure 5).
- Adjust the coupling according to the following specifications in “8 Coupling adjustment”.

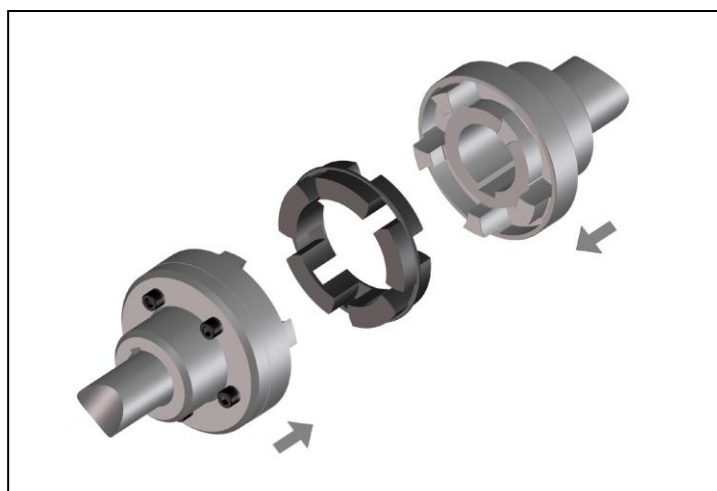

Fig. 5

www.pnp-thietbi.com 0964900401

8 Adjusting coupling



- **Injury hazard!**
- **Switch-off the drive before all work on the coupling!**
- **Secure the drive against unintentional switching on and rotating!**
- **Reference:**
- **An exact alignment of the coupling increases the service life of the elastic intermediate ring and lessens hazards by use.**
- **Do not exceed the maximum permissible displacement values. The overstepping of these values results in coupling damage and breakdown!**



- When aligning the cold equipment take into account the expected thermal growth of the components, so that the permissible misalignment values for the coupling are not exceeded in operation.
- Be aware that the coupling under misalignment imposes restoring forces on the adjacent shafts and bearings. Take into account that the larger the misalignment, the greater the restoring forces will be.
- The displacements values indicated in the tables 2 to 4 are maximum permissible guide numbers.
We recommend not to fully utilise these values during the alignment, so that in operation sufficient reserves remain for thermal expansions, foundation settlements etc.
- In special cases with high demands on quiet running or high rotating speeds it is possible that, in the three displacement levels, an alignment accuracy of $\leq 0,1$ mm is necessary.
- If the coupling is mounted in a closed housing / casing so that a subsequent alignment is not possible any more, it must be guaranteed that the geometry and fit accuracy of the contact surfaces in operation aligns the shafts exactly within the mentioned tolerances.

8.1 Angular misalignment ΔK_w

- Measure on the face of the external diameter a complete rotation (360°). Determine in this case the greatest deviation ΔK_{w1} as well as the smallest deviation ΔK_{w2} (Figure 6).
- Calculate the angular misalignment $\Delta K_w = \Delta K_{w1} - \Delta K_{w2}$.
- The values in table 2 are valid for a reference rotation speed of 1500 min^{-1} .

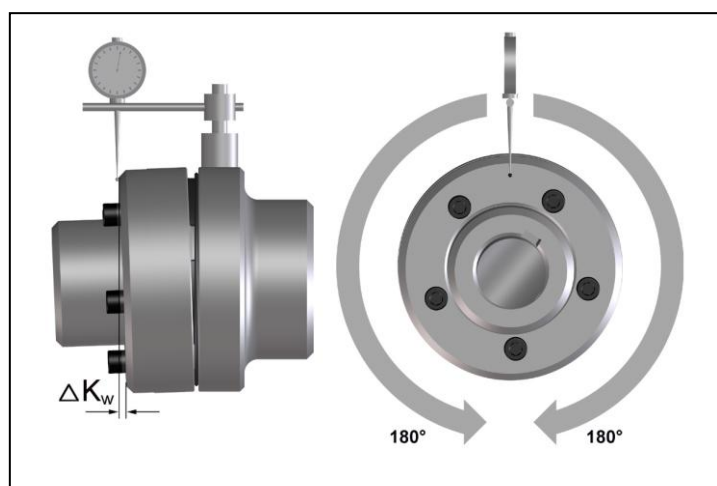

Fig. 6

Table 2 Maximum permissible displacement values - angular:

Size	82	97	112	128	148	168	194	214	240	265	295	330	370	415	480	575
$\Delta K_{w \text{ max}}$ [mm]	0,2	0,2	0,3	0,3	0,3	0,3	0,3	0,3	0,3	0,3	0,3	0,3	0,3	0,3	0,3	0,3

8.2 Radial displacement ΔK_r

- Measure a complete rotation (360°). Determine in this case the greatest deviation ΔK_{r1} as well as the smallest deviation ΔK_{r2} (Figure 7).
- Calculate the radial displacement $\Delta K_r = 0,5 \times (\Delta K_{r1} - \Delta K_{r2})$. Pay attention to the operational sign of the measured values.
- The values of table 3 are valid for a reference rotation speed of 1500 min^{-1} .

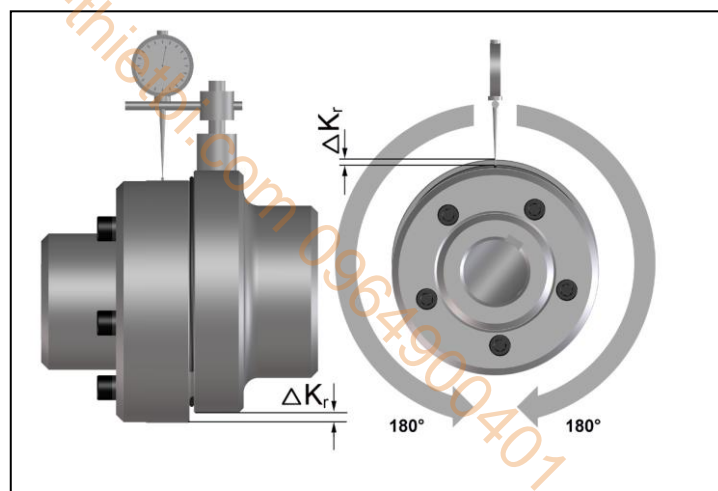

Fig. 7

Table 3 Maximum permissible displacement values - radial:

Size	82	97	112	128	148	168	194	214	240	265	295	330	370	415	480	575
$\Delta K_{r \text{ max}}$ [mm]	0,2	0,2	0,3	0,3	0,3	0,3	0,3	0,3	0,3	0,3	0,3	0,3	0,3	0,3	0,3	0,3

8.3 Axial displacement

- Measure the axial S gap measurement according to figure 8.
- Keep, when aligning the gap measurement S, to the maximum permissible tolerance X according to table 4.

ATTENTION!

If greater axial displacements are expected in operation, consultation with RINGFEDER POWER TRANSMISSION is necessary.

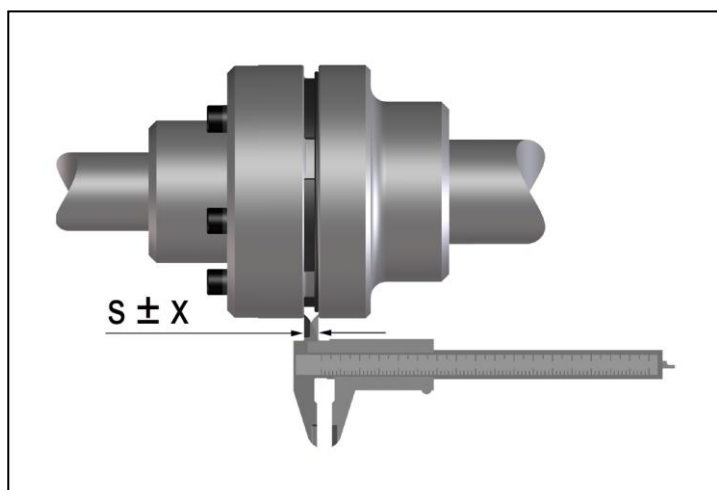

Fig. 8

Table 4 Recommended alignment values - axial:

Size	82	97	112	128	148	168	194	214	240	265	295	330	370	415	480	575
S [mm]	3	3	3,5	3,5	3,5	3,5	3,5	4	4	5,5	8	8	8	8	8	8
X [mm]	±1	±1	±1	±1	±1	±1,5	±1,5	±2	±2	±2,5	±2,5	±2,5	±2,5	±2,5	±2,5	±2,5

9 Operation

When using the coupling attention is to be paid to its characteristics (see „6 Technical data“). These can in no case be exceeded without having a written agreement from RINGFEDER POWER TRANSMISSION. In order to guarantee a faultless, lasting operation of the coupling, it must be laid out according to the regulations e.g. DIN 740 part 2 (or according to Product Paper & Tech Paper „Elastomer Jaw Couplings“) with an operating factor corresponding to its operating conditions. Every change of the conditions of use or the operating parameters makes an inspection of the coupling layout urgently necessary.



- **Injury danger!**
- **Switch-off the drive before all work on the coupling!**
- **Secure the drive against unintentional switch-on and rotating!**
- **Due to incorrectly tightened screws parts can fly away and cause serious injuries to persons and damage to material!**
- **Check before commissioning the coupling the alignment and all screw fastenings for their specified tightening torque and/or firm seating!**
- **Before commissioning the plant install all protective devices against unintentional touching of free moving and/or rotating parts.**
- **To avoid sparks coverings in stainless steel should be used!**
- **The coverings must fulfil at least the protection type IP2X.**
- **The covering is to be so designed that it does not deposit dust onto the coupling parts.**
- **The covering must not touch the coupling or influence it in its functioning.**

Pay attention during the operation of the coupling to:

- Changed running noises
- Occurring vibrations

Attention!

- **If irregularities are found during operation of the coupling, the drive must be immediately switched off.**
- Detect according to the following table 5, „Operating faults and their possible causes“ the faults and remove.
The listed faults are some examples which are supposed to facilitate fault location.
- **For fault finding and elimination all machine components and operating states are to be considered!**

Table 5 Operating faults and their possible causes:

Trouble	Cause	Risk Warning	Correction
Irregular running noises/vibrations	Alignment fault	Considerable increase in coupling temperature. Premature wear of elastic buffers. Increased reaction forces act on connected machines.	<ul style="list-style-type: none"> - Disconnect drive - Remove cause for alignment fault - Re-align coupling - Inspect elastomer for wear
	Elastomer worn out	Coupling claws strike against each other. Spark formation, claw fracture, increased reaction forces.	<ul style="list-style-type: none"> - Disconnect drive - Check coupling components for damages and replace parts, if necessary - Replace elastomer
	Unbalance	Considerable increase in coupling temperature. Premature wear of elastic buffers. Increased reaction forces act on connected machines	<ul style="list-style-type: none"> - Disconnect drive - Verify balance state of plant components and correct it, if necessary - Inspect elastomer for wear
	Loose screw connections	Flying off parts can cause serious injuries and considerable damages.	<ul style="list-style-type: none"> - Disconnect drive - Check coupling parts for damages, replace parts, if necessary - Verify alignment of coupling - Tighten screws to the specified tightening torque and secure them against working loose, if necessary, - Inspect elastomer for wear
Premature wear of elastomer	Alignment fault	Considerable increase in coupling temperature. Increased reaction forces act on connected machines.	<ul style="list-style-type: none"> - Disconnect drive - Remove cause for alignment fault - Re-align coupling - Inspect elastomer for wear

Trouble	Cause	Risk Warning	Correction
	Unacceptable temperatures	Material properties of elastic buffers change. The torque transmission capability is adversely affected.	<ul style="list-style-type: none"> - Disconnect drive - Replace elastomer - Re-align coupling - Adjust ambient temperature
	Contact with aggressive products	Material properties of elastic buffers change. The torque transmission capability is adversely affected.	<ul style="list-style-type: none"> - Disconnect drive - Check coupling parts for damages and replace parts, if necessary - Replace elastomer - Verify alignment of coupling - Prevent contact with aggressive products
	Torsional vibrations in the drive line	Considerable increase in coupling temperature. Premature wear of elastic buffers. Increased reaction forces act on connected machines.	<ul style="list-style-type: none"> - Disconnect drive - Analyse and eliminate cause for torsional vibrations - Check coupling parts for damages and replace parts, if necessary - Replace elastomer and consult RINGFEDER POWER TRANSMISSION concerning eventual use of another Shore-hardness - Verify coupling alignment
Claw breakage	Wear limit of elastomer exceeded ==> contact of claws	Coupling is destroyed. Connected machines can be affected, too.	<ul style="list-style-type: none"> - Disconnect drive - Replace coupling - Inspect the elastomer for wear at shorter intervals
	Overload due to too high torque	Coupling is destroyed. Connected machines can be affected, too.	<ul style="list-style-type: none"> - Disconnect drive - Verify coupling design in cooperation with RINGFEDER POWER TRANSMISSION - Replace coupling - Install larger coupling, if necessary

9.1 Sense of rotation test



- **Injury danger!**
- **Switch-off the drive before all work on the coupling!**
- **Secure the drive against unintentional switching on and rotating!**
- **Due to incorrectly screwed on screws, parts can fly away and cause person and material damage!**
- **Check before commissioning the coupling the alignment and all screw fixings for their specified tightening torque and/or firm seating!**
- **Before commissioning the plant all protective devices against unintentional touching of free moving and/or rotating parts must be installed.**
- **To avoid sparks coverings should be made of stainless steel!**
- **The coverings must fulfil at least the protection type IP2X.**
- **The covering is to be designed in such a way that it does not deposit dust onto the coupling parts.**
- **The covering must not touch the coupling and/or influence it in its function.**



- **Attention!**
- **A sense of rotation test can only be carried out if the coupling flange is mounted onto the aggregate drive-side! Otherwise sparking hazards exist through the pushed back claw ring!**

- Remove the fixing screws on the claw ring and push it back (Figure 9, Pos. 1).
- Secure the claw ring against unintentional displacement.
- Cut through the intermediate ring at a connecting part (Figure 9, pos. 2).
- Pull out the intermediate ring. Start at the cut through connecting part.

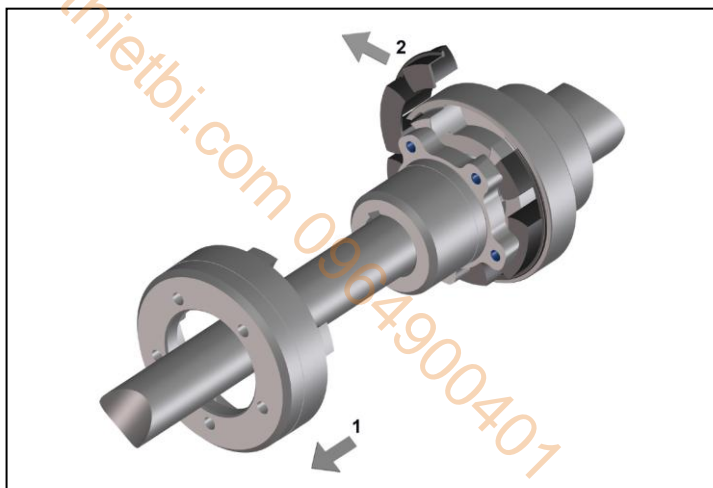

Fig. 9

- **Attention!**
- **Make sure, that the coupling halves can not move axially during the sense of rotation test.**
- **The coupling half with the pulled back claw ring must remain stationary during the sense of rotation test.**
- **The rotating half must not touch the stationary half!**

- After the sense of rotation test, cut through a new intermediate ring at a connecting part and fit it between coupling hub and flange.
- To obtain an easier mounting one can provide the new elastic intermediate ring with a slip additive before its introduction (e.g. talcum powder).

Attention!

The bearing surface of the claw ring and flange hub must be clean, dry and grease-free. Balanced parts are position marked to each other.

- Mount the claw ring into its marked position. When doing this pay attention also that the parts not tilt when being joined to the centering seat.
- Slightly tighten the screws uniformly.
- Tighten the claw ring threaded joint with the tightening torque M_A stipulated in table 6 (Figure 10).
- Check the alignment of the coupling according to the specifications in „8 Coupling adjustment“.

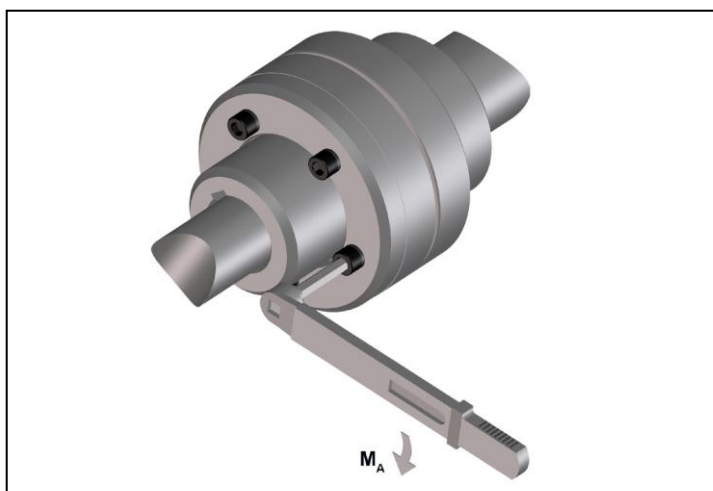

Fig. 10

Table 6 Tightening torques M_A of the bolting of the claw ring:

Size	82	97	112	128	148	168	194	214	240	265	295	330	370	415	480	575
DIN 912- 8.8	M6	M6	M8	M8	M10	M10	M10									
DIN 912-10.9								M12	M12	M14	M14	M16	M16	M16	M20	M20
M_A [Nm]	10	10	25	25	49	49	49	125	125	200	200	310	310	310	610	610

Observe reduced tightening torques for the bolting of the claw ring if coupling parts are phosphated and oiled!

Size	82	97	112	128	148	168	194	214	240	265	295	330	370	415	480	575
DIN 912- 8.8	M6	M6	M8	M8	M10	M10	M10									
DIN 912-10.9								M12	M12	M14	M14	M16	M16	M16	M20	M20
M_A [Nm]	8,3	8,3	20	20	40	40	40	100	100	160	160	240	240	240	490	490

10 Maintenance

The elastic coupling RINGFEDER® TNM G has in operation a low-maintenance. Reaching the wear limit of the elastic intermediate ring depends on the operating parameters and the conditions of use.

In the case of routine monitoring work on the plant check:

- Alignment of the coupling
- Elastomer state
- Remove dust deposits from the coupling parts and the intermediate ring

10.1 Wear Inspection on the Buffer Ring



- **Danger of injuries!**
- **Disconnect the drive before carrying out any work on the coupling!**
- **Secure the drive against unintentional switching on and rotating!**

Perform a visual inspection and a wear inspection of the buffer ring after 2000 hours, or after 3 months at latest, after the first start-up of the equipment. If only minor wear or no wear is observed, further inspections of the plant can be carried out at regular intervals of 4000 hours, however, at least once a year, if the operating modes and conditions of the plant remain unchanged. However, should you observe excessive wear on the occasion of this first inspection already, check whether the cause for the problem is listed in table 5 "Operation faults and possible causes". In such a case, the inspection intervals must be adapted to the prevailing service conditions.

On the occasion of routine inspections or maintenance work on the drive equipment, or after 3 years at latest:

- Replace the elastic buffer ring.
- If the wear limit has been reached or exceeded, replace the buffer ring immediately, irrespective of the inspection intervals of the equipment.
- Check the alignment of the coupling.
- Remove dust deposits from the coupling components and buffer ring.

10.2 Wear limit of elastic buffers

Replace the elastic buffer ring as soon as the coupling has a distinct torsional backlash, or if the minimum buffer thickness (PD_{min} , Fig. 11) acc. to table 7 has been reached.

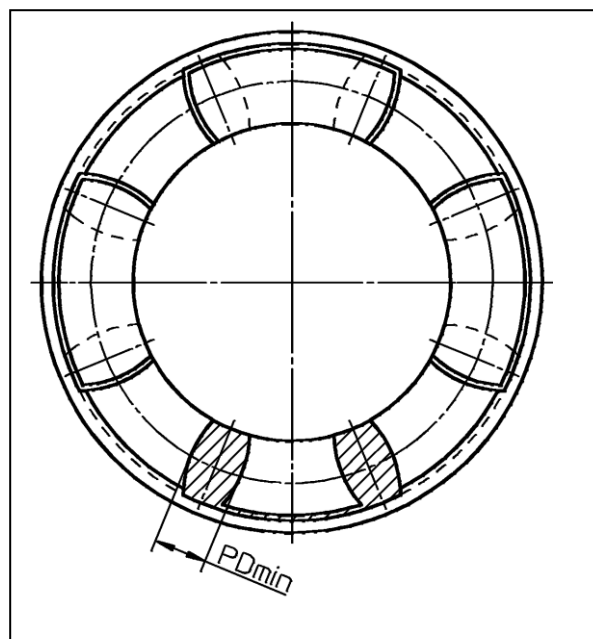

Fig. 11 Buffer thickness

Table 7 Minimum buffer thickness PD_{min} :

Size	82	97	112	128	148	168	194	214	240	265	295	330	370	415	480	575
PD_{min} [mm]	8	9	9	9	10	10	10	10	11	12	13	14	16	17	17	17

10.3 Changing the elastic intermediate ring



- **Injury hazard!**
- **Switch-off the drive before all work on the coupling!**
- **Secure the drive against unintentional switching on and rotating!**

- Remove the holding-down screws on the claw ring and push it back (Figure 12, Pos. 1)
- Cut through the intermediate ring at a connecting joint (Figure 12, Pos. 2)
- Pull out the intermediate ring. Begin at the cut through connecting joint.
- For easier mounting, the new intermediate ring can be provided with a slip additive before introduction (e.g. Talcum powder).
- Cut through the new intermediate ring at a connecting joint and position it between coupling flange and flange hub.

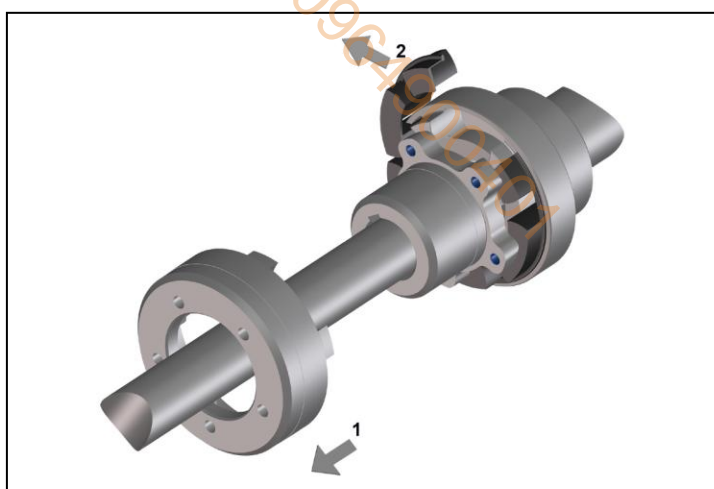

Fig. 12

Attention!

The bearing surfaces of the claw ring and flange hub must be clean as well as oil and grease-free. Balanced parts are position marked to each other.

- Mount the claw ring into its marked position. When doing this pay attention also that the parts not tilt when being joined to the centering seat.
- Tighten the screws slightly.
- Tighten up the claw ring threaded joints with the tightening torque M_A stipulated in table 8 (Figure 13).
- Check the alignment of the coupling according to “8 Coupling adjustment”.

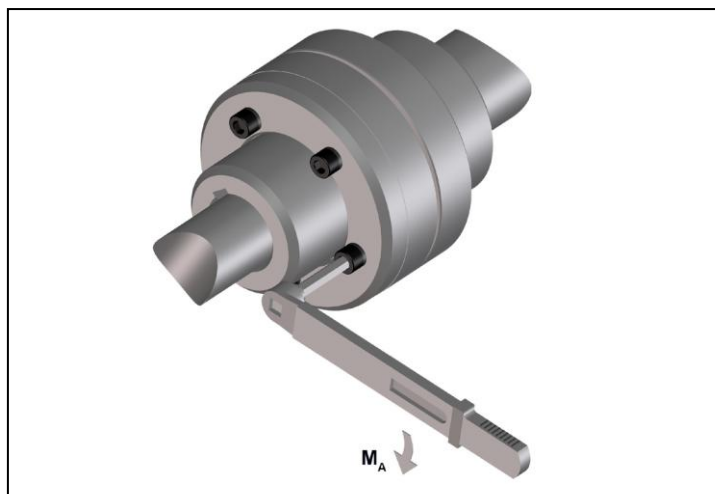

Fig. 13

Table 8 Tightening torques M_A for the bolting of the claw ring:

Size	82	97	112	128	148	168	194	214	240	265	295	330	370	415	480	575
DIN 912- 8.8	M6	M6	M8	M8	M10	M10	M10									
DIN 912-10.9								M12	M12	M14	M14	M16	M16	M16	M20	M20
M_A [Nm]	10	10	25	25	49	49	49	125	125	200	200	310	310	310	610	610

Observe reduced tightening torques for the bolting of the claw ring if coupling parts are phosphated and oiled!

Size	82	97	112	128	148	168	194	214	240	265	295	330	370	415	480	575
DIN 912- 8.8	M6	M6	M8	M8	M10	M10	M10									
DIN 912-10.9								M12	M12	M14	M14	M16	M16	M16	M20	M20
M_A [Nm]	8,3	8,3	20	20	40	40	40	100	100	160	160	240	240	240	490	490

Warning!



- Before commissioning the plant install all protective devices against unintentional touching of free rotating parts.
- To avoid sparks coverings in stainless steel should be used.
- The coverings must fulfil at least the protection type IP2X.
- The covering is to be so designed that it does not deposit dust onto the coupling parts.
- The covering must not touch the coupling or influence it in its functioning.

When using accessories and spare parts which were not originally manufactured by RINGFEDER POWER TRANSMISSION, no liability or guarantee for any damages will be accepted.

11 Waste Disposal

The waste disposal has to occur according to the specific regulations of the respective user country.

phucnguyenphat www.pnp-thietbi.com 0964900401

phucnguyenphat www.pnp-thietbi.com 0964200407

RINGFEDER POWER TRANSMISSION GMBH

Werner-Heisenberg-Straße 18, 64823 Groß-Umstadt, Germany · Phone: +49 6078 9385-0 · Fax: +49 6078 9385-100
E-Mail: sales.international@ringfeder.com

RINGFEDER POWER TRANSMISSION SP. Z O. O.

Ul. Szyby Rycerskie 6, 41-909 Bytom, Poland · Phone: +48 32 301 53 00 · Fax: +48 32 722 44 44 · E-Mail: sales.poland@ringfeder.com

RINGFEDER POWER TRANSMISSION USA CORP.

291 Boston Turnpike, Bolton, CT 06043, USA · Toll Free: +1 888 746-4333 · Phone: +1 201 666-3320 · Fax: +1 860 646-2645
E-Mail: sales.usa@ringfeder.com

CARLYLE JOHNSON MACHINE COMPANY, LLC.

291 Boston Turnpike, Bolton, CT 06043, USA · Phone: +1 860 643-1531 · Fax: +1 860 646-2645 · E-Mail: info@cjmco.com

HENFEL INDÚSTRIA METALÚRGICA LTDA.

Av. Maj. Hilário Tavares Pinheiro 3447, Pq. Ind. Carlos Tonanni, CEP 14871-300, Jaboticabal, SP, Brazil · Phone: +55 (16) 3209-3422
E-Mail: vendas@henfel.com.br

RINGFEDER POWER TRANSMISSION INDIA PVT. LTD.

Plot No. 4, Door No. 220, Mount Poonamallee Road, Kattupakkam, Chennai, 600 056, India · Phone: +91 44 2679-1411
Fax: +91 44 2679-1422 · E-Mail: sales.india@ringfeder.com

KUNSHAN RINGFEDER POWER TRANSMISSION CO. LTD.

No. 406 Jiande Road, Zhangpu 215321, Kunshan, Jiangsu Province, China · Phone: +86 512 5745-3960 · Fax: +86 512 5745-3961
E-Mail: sales.china@ringfeder.com