

T10 Type

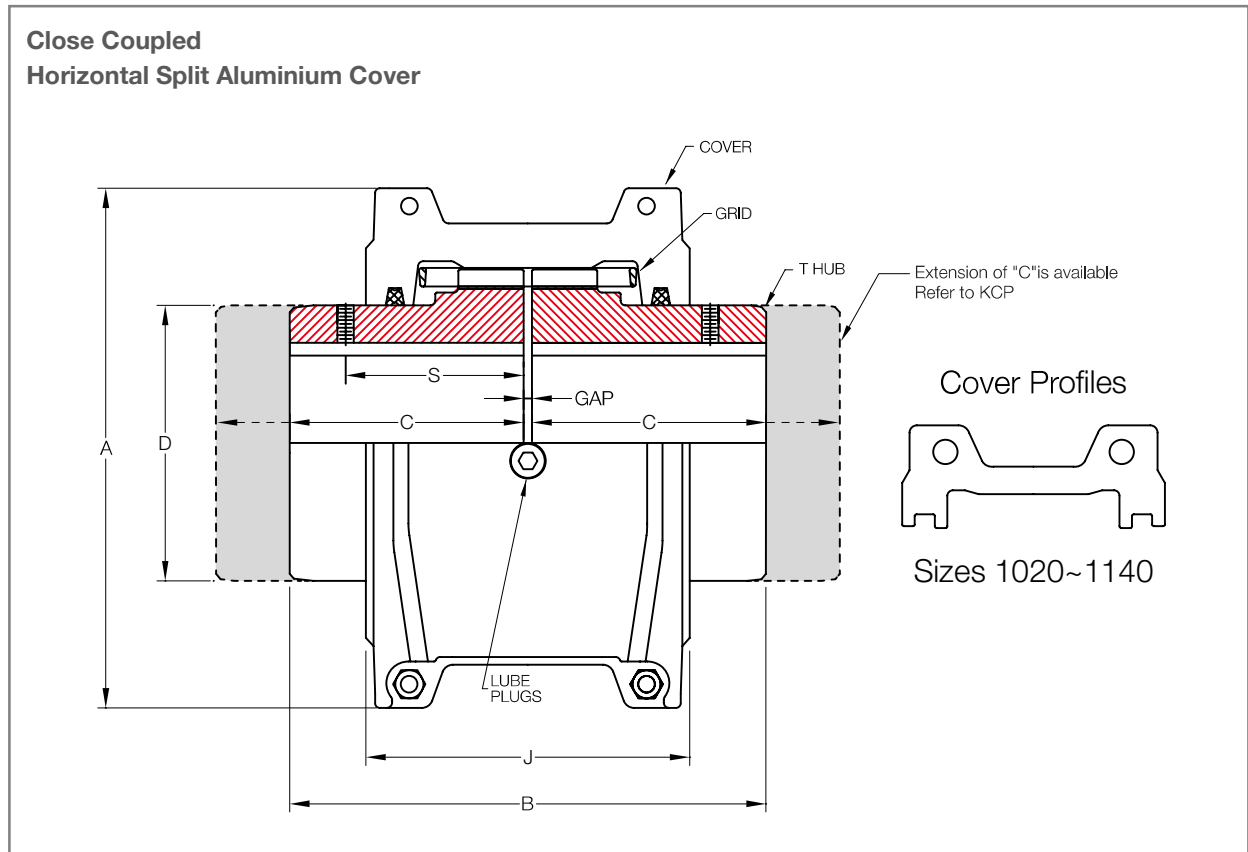

Size	Torque Rating (Nm)	Allow Speed RPM	Max Bore (mm)	Min Bore (mm)	Cplg Weight (Kg)	Lube Weight (Kg)	Dimensions (Millimeters)							Size
							A	B	C	D	J	S	GAP	
1020	52	4,500	28	13	1.92	0.0272	101.0	98.2	47.6	39.7	67.8	39.1	3	1020
1030	149	4,500	35	13	2.58	0.0408	109.0	98.2	47.6	49.2	71.9	39.1	3	1030
1040	249	4,500	43	13	3.34	0.0544	116.0	104.6	50.8	57.2	72.0	40.1	3	1040
1050	435	4,500	50	13	5.44	0.0680	137.8	123.6	60.3	66.7	81.6	44.7	3	1050
1060	684	4,350	56	20	7.44	0.0862	147.0	130.0	63.5	76.2	97.9	52.3	3	1060
1070	994	4,125	67	20	10.40	0.113	162.2	155.4	76.2	87.3	99.2	53.8	3	1070
1080	2,050	3,600	80	27	17.90	0.172	193.0	180.8	88.9	104.8	118.4	64.5	3	1080
1090	3,730	3,600	95	27	25.60	0.254	212.0	199.8	98.4	123.8	127.4	71.6	3	1090
1100	6,280	2,440	110	42	42.00	0.426	250.7	246.2	120.6	142.1	156.6	-	5	1100
1110	9,320	2,250	120	42	54.30	0.508	270.0	259.0	127.0	160.3	162.6	-	5	1110
1120	13,700	2,025	140	61	81.20	0.735	306.4	304.4	149.2	179.4	191.7	-	6	1120
1130	19,900	1,800	170	67	121.00	0.907	343.8	329.8	161.9	217.5	195.5	-	6	1130
1140	28,600	1,650	200	67	178.00	1.130	383.8	374.4	184.2	254.0	201.7	-	6	1140

* Coupling Weight is without Bore Machining