

TYPE BWT

Variant B

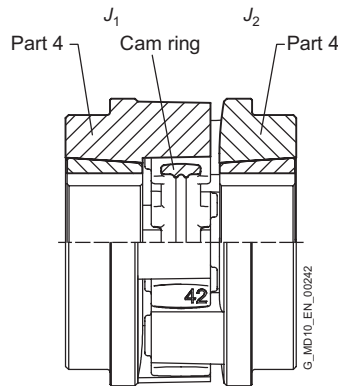

Variant B

9

Size	Taper Clamping Bush Size	Rated torque		Speed n_{Kmax} rpm	Dimensions in mm										Mass moment of inertia J_1/J_2 kgm ²	Article no. ¹⁾ Type B	Weight m kg
		T_{KN}			D1/D2 Keyway DIN 6885	DA	ND1/ ND2	NL1/ NL2	D3	S	S2	ΔS2	LG				
		92 ShoreA Nm	95 ShoreA Nm											min.			
24	1008	45	65	14500	10	25	55	55	23	25	18	37	1.5	64	0.00016	2LC0160-1AC	0.6
28	1108	95	160	12500	10	28	67	58	23	28	20	41	1	66	0.00025	2LC0160-2AC	0.8
38	1108	190	325	10000	10	28	82	58	23	36	24	45	1.5	70	0.0005	2LC0160-3AC	1.2
42	1610	265	450	8500	14	42	97	86	26	43	26	48	1.5	78	0.0013	2LC0160-4AC	1.8
48	1615	330	550	7500	14	42	107	80	39	48	28	50	2	106	0.002	2LC0160-5AC	2.6
55	2012	460	700	6500	14	50	120	100	33	57	30	60	2	96	0.004	2LC0160-6AC	3.8
65	2012	670	1000	6000	14	50	135	100	33	64	35	65	2.5	101	0.007	2LC0160-7AC	5
	2517 ²⁾			55	60	115		46	127					0.008	5.9		
75	2517	1400	2000	5000	16	60	160	118	46	76	40	75	2.5	132	0.02	2LC0160-8AC	8.4
	3020 ²⁾			65	75	135		52	144					0.017	8.3		
90	3020	2500	3700	4000	25	75	205	142	52	95	45	85	3	149	0.037	2LC0161-0AC	12.9
	3535 ²⁾			80	90	170		90	225					0.06	19.8		

Configurable variants ¹⁾

- ØD1 Without Taper clamping bush
With Taper clamping bush
- ØD2 Without Taper clamping bush
With Taper clamping bush
- Cam ring hardness **92 ShoreA**
95 ShoreA

Notes

- Mass moments of inertia apply to a coupling half without Taper clamping bush.
- Weights apply to a whole coupling in the version without taper clamping bush.
- T_{Kmax} for the 95 ShoreA cam ring is limited to $2 \times T_{KN}$ for types BWT and BNT contrary to the table on Page 9/7. When using the 64 ShoreD cam ring, the same torque values apply as for the 95 ShoreA cam ring.

Ordering example

- N-BIPEX BWT coupling, size 42, variant B
- Part 3: With Taper clamping bushes, size 1610, bore D1 38 H7 mm, with keyway to DIN 6885-1
- Part 4: With Taper clamping bushes, size 1610, bore D2 32 H7 mm, with keyway to DIN 6885-1
- Cam ring hardness 92 ShoreA

Article no.: 2LC0160-4AC99-0AA0-Z L0V+M0T

¹⁾ To identify complete item numbers specifying the available finish boring options and – if necessary – further order options, please use our configurators on flender.com.

²⁾ Taper clamping bush version only possible in part 4.

➤ For online configuration on flender.com, click on the item no.